



TAMPERE UNIVERSITY OF TECHNOLOGY
Ragnar Granit Institute

Bioelectromagnetism

Exercise #1 – Answers

Q1: Equilibrium Voltages

- In nerve and muscle cells the concentration ratios of the chloride and potassium ions between intracellular and extracellular fluids are approximately 1:30 (that is, for example $4 \times 10^{-6} : 120 \times 10^{-6} \text{ mol/cm}^3$) and 38.8:1. What are the corresponding equilibrium voltages for chloride and potassium ions? (The value of the potential difference across the cell membrane that clamps the specific ionic flow)

Q1: Equilibrium Voltages

- Nernst equation separately for both ion types

$$\Delta V = -\frac{RT}{zF} \ln \frac{c_i}{c_o}$$

- $R = 8.314 \text{ J}/(\text{mol}\cdot\text{K})$
- $T = 37^\circ\text{C} = 273 + 37 \text{ K} = 310 \text{ K}$
- $F = 9.649 \cdot 10^4 \text{ C/mol}$

- **For Cl⁻:**
$$V_{Cl} = -\frac{8.314 \cdot 310}{-1 \cdot 96485} \ln \frac{1}{30} = \mathbf{-90.9 \text{ mV}}$$

- **For K⁺:**
 - $c/c_o = 38.8 / 1$
 - $z = +1$

$$V_K = \mathbf{-97.7 \text{ mV}}$$

Q2: Resting Membrane Potential

- The permeabilities of potassium, sodium and chloride ions in the giant axon of a squid at 36 °C are $P_K:P_{Na}:P_{Cl} = 1:0.04:0.45$. The concentrations of the ions in intracellular and extracellular fluids are [10^{-3} mol/cm³]:

$$[K^+]_i = 3.45$$

$$[Na^+]_i = 0.72$$

$$[Cl^-]_i = 0.61$$

$$[K^+]_o = 0.10$$

$$[Na^+]_o = 4.55$$

$$[Cl^-]_o = 5.40$$

Determine the resting membrane potential.

Q2: Resting Membrane Potential

■ Background

- permeability differs among ions species
- > selective permeability -> concentration gradients - > GHK-equation
- Nernst for one ion type. Goldman-Hodgin-Katz for several ion types:

$$V_m = -\frac{RT}{F} \ln \left(\frac{P_{K,i,K} c_{i,K} + P_{Na,i,Na} c_{i,Na} + P_{Cl,o,Cl} c_{o,Cl}}{P_{K,o,K} c_{o,K} + P_{Na,o,Na} c_{o,Na} + P_{Cl,i,Cl} c_{i,Cl}} \right) = ?$$

$$R = 8.314 \text{ J}/(\text{mol} \cdot \text{K})$$

$$F = 96485 \text{ J}/\text{mol}$$

$$T = 309 \text{ K}$$

Q2: Resting Membrane Potential

- Resting membrane potential:

$$V = -\frac{RT}{F} \ln \left(\frac{P_{K,i,K} c_{K,i,K} + P_{Na,i,Na} c_{Na,i,Na} + P_{Cl,o,Cl} c_{Cl,o,Cl}}{P_{K,o,K} c_{K,o,K} + P_{Na,o,Na} c_{Na,o,Na} + P_{Cl,i,Cl} c_{Cl,i,Cl}} \right) = ?$$

- i) **NO z**
- ii) **== Nernst eq for K, if $c_{Na,Cl} = 0$**
- iii) **equilibrium = $J_K + J_{Na} + J_{Cl} = 0$**

- RESULT:** $V_m = -0.0629 \text{ V} \approx -63 \text{ mV}$

Q3: Chloride Pump

- A special single cell organism that lives in a natural mineral water spring has permeabilities of 0.09, 1.00 and 0.04 for the Cl^- , K^+ and Na^+ , respectively, and the following concentrations

$$[\text{Cl}^-]_i = 178$$

$$[\text{K}^+]_i = 135$$

$$[\text{Na}^+]_i = 0.05$$

$$[\text{Cl}^-]_o = 0.47$$

$$[\text{K}^+]_o = 83$$

$$[\text{Na}^+]_o = 118$$

To *maintain* the chloride gradient, this cell has a special chloride pump. Which direction does the pump have to move chloride in order to maintain the status?

- Solution: pump will have to counteract the net force (C+E)
 - GHK = resting potential
 - Nernst for Cl^-

Q3: Chloride Pump

- RMP (25 C°)

$$V = -\frac{RT}{F} \ln \left(\frac{P_{K,i,K} c_{Na,i,Na} + P_{Cl,o,Cl} c_{K,o,K}}{P_{K,o,K} c_{Na,o,Na} + P_{Cl,i,Cl} c_{K,i,K}} \right) = ?$$

$$\Rightarrow V = -6.8 \text{ mV}$$

- Nernst for Cl⁻:

$$V_{Cl^-} = -\frac{RT}{zF} \ln \frac{c_i}{c_o} = 152 \text{ mV}$$

- Driving force $\Delta V = \text{RMP} - V_{Cl} = -158.8 \text{ mV}$
 - negative ion: force to the outside
 - Cl⁻ leaking outside

- **Answer:**

The pump must counteract driving force and pump chloride into the cell to maintain the chloride gradient.

Q4: RMP

- Show that the resting potential of the cell membrane can be expressed as

$$V = \frac{g_K V_K + g_{Na} V_{Na} + g_{Cl} V_{Cl}}{g_K + g_{Na} + g_{Cl}}$$

where

g_i = membrane conductance for ions i ,

V_i = equilibrium voltage for ions i .

Q4: RMP

■ When the membrane is at resting state: $\Sigma I_j = 0$

■ $I_K + I_{Na} + I_{Cl} = 0$

■ $I = U/R, g = 1/R$

■ E.g. for potassium: $I_K = g_K U = g_K (V_m - V_K)$

■ For all currents:

$$g_K (V_m - V_K) + g_{Na} (V_m - V_{Na}) + g_{Cl} (V_m - V_{Cl}) = 0$$

$$\Rightarrow V_m = \frac{g_K V_K + g_{Na} V_{Na} + g_{Cl} V_{Cl}}{g_K + g_{Na} + g_{Cl}}$$

Q5: Synapse

- Figure 1 represents an electrical model of a synapse. When impulse arrives to the presynaptic terminal the transmitter (acetylcholine ACh) is released to the synaptic cleft (after 0.5 ms). The cell membrane will become permeable to Na⁺ and K⁺ ions and the membrane potential tends to shift towards the mean of the Nernst voltages of the Na⁺ and K⁺ ions (=reversal voltage V_{rev}).

- What is the resting potential of the presynaptic terminal (ACh-switch open)?
- What is the reversal voltage, V_{rev} (ACh-switch closed)?

C_m (membrane capacitance per area) = 1 $\mu\text{F}/\text{cm}^2$

Nernst voltages $V_K = -100 \text{ mV}$ and $V_{Na} = 60 \text{ mV}$

$R_K = 10^8 \Omega$, $R_{Na} = 1.5 \cdot 10^9 \Omega$, $\Delta R_K = 10^5 \Omega$, $\Delta R_{Na} = 10^5 \Omega$.

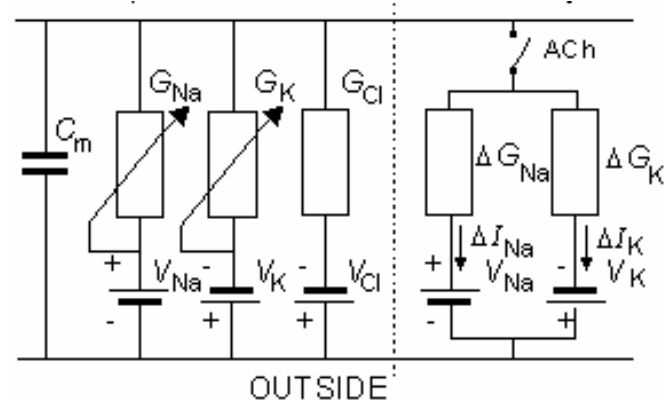
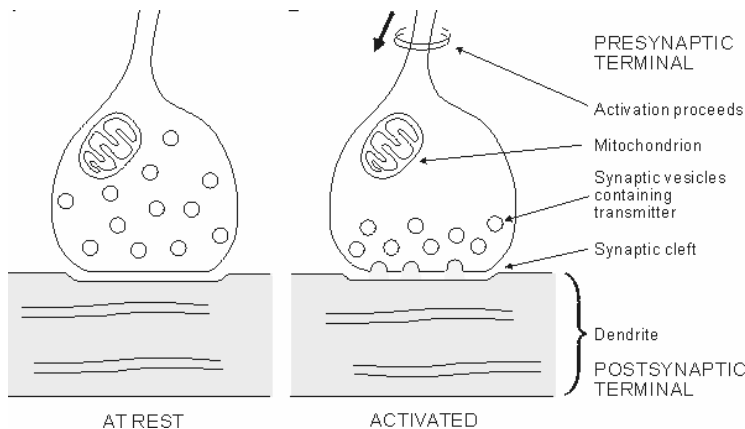

Q5: Synapse

- Information from neuron to another flows across a synapse. The synapse consists of:
 - a presynaptic ending (contains neurotransmitters),
 - a postsynaptic ending that contains receptor sites for neurotransmitters and,
 - the synaptic cleft: a space between
- Neurotransmitters
 - chemicals that cross the synapse between two neurons
 - ΔG_i

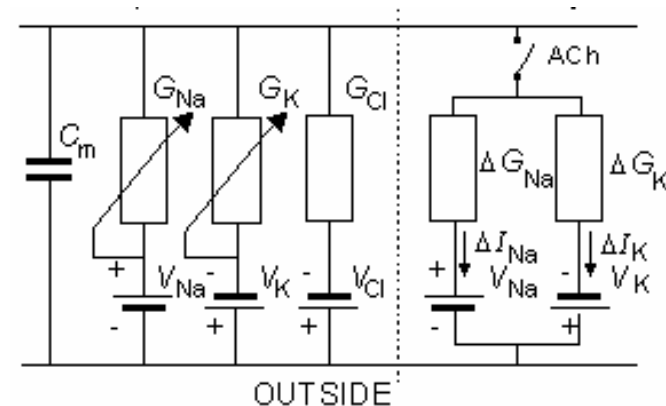
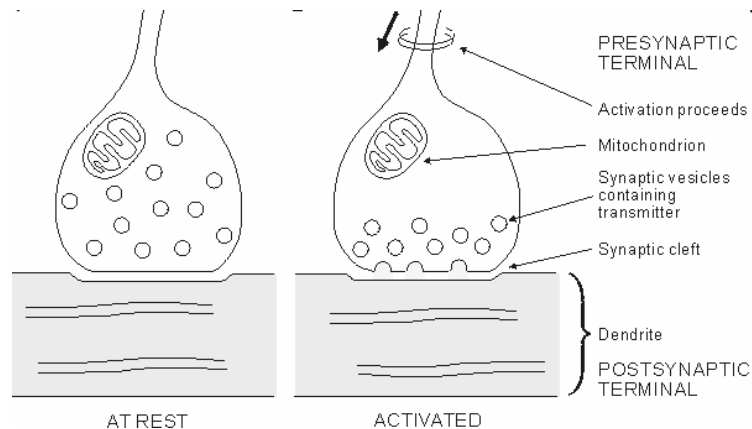

Q5: Synapse

■ a) What is the resting potential of the presynaptic terminal (ACh-switch open)?

– Ignored:

- Na-K pumps
- Leakage I ($\sim I_{Cl}$)

– steady-state:

- $i_K + i_{Na} = 0$
- $i_K = G_K(V_m - V_K)$
- $i_{Na} = G_{Na}(V_m - V_{Na})$

- $G_K(V_m - V_K) = -G_{Na}(V_m - V_{Na})$

- $V_m = (G_{Na}V_{Na} + G_KV_K)/(G_K + G_{Na})$

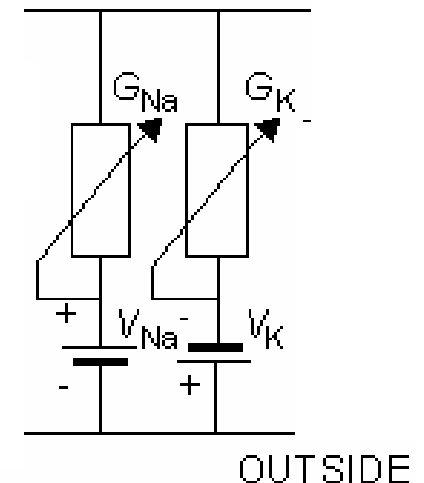
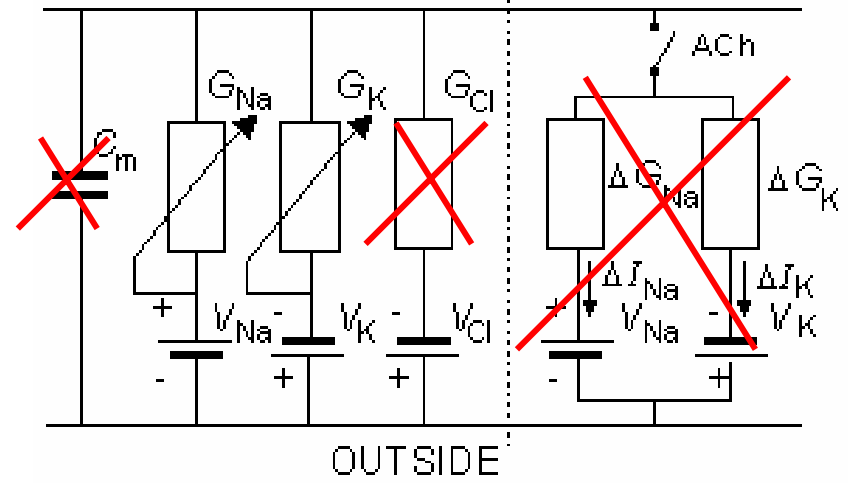

Q5: Synapse

Convert from R to G:

$$R_K = 10^8 \Omega \Rightarrow G_K = 1/R_K = 10^{-8} \text{ S}$$

$$R_{Na} = 1.5 \cdot 10^9 \Omega \Rightarrow G_{Na} = 6.7 \cdot 10^{-10} \text{ S}$$

$$V_{Na} = 60 \text{ mV}$$

$$V_K = -100 \text{ mV}$$

$$\begin{aligned} V_m &= (G_{Na} V_{Na} + G_K V_K) / (G_K + G_{Na}) \\ &= -90 \text{ mV} \end{aligned}$$

Q5: Synapse

■ b) What is the reversal voltage, V_{rev} (ACH-switch closed)?

■ $\Sigma I=0$ after the release of ACh

■ $i_K + i_{Na} = 0$

■ $i_K = (G_K + \Delta G_K) * (V_r - V_K) = G'_K * (V_r - V_K)$

■ $i_{Na} = (G_{Na} + \Delta G_{Na}) * (V_r - V_{Na}) = G'_{Na} * (V_r - V_{Na})$

■ $G'_K * (V_r - V_K) = - G'_{Na} * (V_r - V_{Na})$

■ $V_r = (G'_{Na} V_{Na} + G'_K V_K) / (G'_K + G'_{Na})$

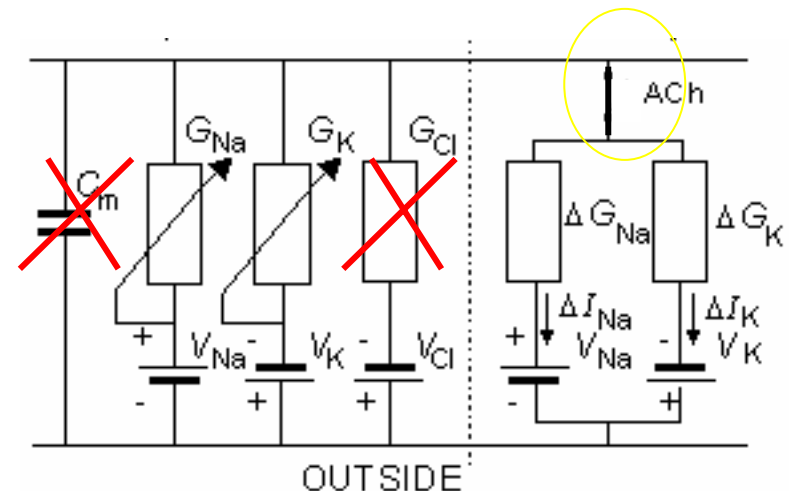

Q5: Synapse

- $V_r = (G'_{Na} V_{Na} + G'_K V_K) / (G'_K + G'_{Na})$

- $G'_{Na} = G_{Na} + \Delta G_{Na}$

- $G'_K = G_K + \Delta G_K$

- $\Delta R_K = 10^5 \Omega \Rightarrow \Delta G_K = 10^{-5} S$

- $\Delta R_{Na} = 10^5 \Omega \Rightarrow \Delta G_{Na} = 10^{-5} S$

- $G_K = 10^{-8} S$

- $G_{Na} = 6.7 * 10^{-10} S$

- $G'_K = 1.0011 * 10^{-5} S$

- $G'_{Na} = 1.0001 * 10^{-5} S$

- $V_{Na} = 60 mV$

- $V_K = -100 mV$

$$V_r = \frac{\frac{G'_{Na}}{G'_K} V_{Na} + V_K}{\frac{G'_{Na}}{G'_K} + 1}$$

$$\frac{G'_{Na}}{G'_K} \approx 1$$

$$V_r \approx \frac{V_{Na} + V_K}{2} \approx -20 mV$$